

Valve regulation assistance

by **Spraying Systems Co, USA**

A new Valve Regulation Package has been helping cement producers ensure optimal performance of spray nozzles and lances in gas conditioning. Spraying Systems Inc, the creators of this package, describe the design and application process of the new pre-assembled system through results of installations at Zhejiang Cement in China, plus Lafarge North America and Holcim (Inc) USA.

A new pre-assembled package configured with the components required to operate and regulate dual-fluid spray nozzles and lances in gas conditioning applications is now available from Spraying Systems Co. The pre-assembled package includes ball valves, check valves, pressure gauges, regulators and analogue flow meters mounted on a rack and ready for installation. All system components are sized based on the capacity of the spray nozzles and placed strategically on the rack to ensure optimal performance.

The Valve Regulation Package is designed to eliminate performance problems in gas conditioning systems caused by the use of undersized valves, improperly sized piping and incorrect placement of gauges. These common mistakes can result in poor spray nozzle performance, increased energy and compressed air costs and the use of higher pressure pumps. The new Valve Regulation Package not only ensures optimal performance, but also eliminates the need for plant personnel to research, size, source and install a variety of components from different manufacturers – a time-consuming process with little margin for error.

Ideal for use with FloMax[®] Air Atomising nozzles and lances in gas conditioning applications, the Valve Regulation Package can be used with any air atomising nozzle with liquid flows ranging from 0.5 to 75gpm (1.9 to 284l/min). Spraying Systems Co's sales engineers will provide specification assistance based on the total liquid and air flow rate, liquid and air inlet pressures, pipe size and number of spray lances to be controlled.

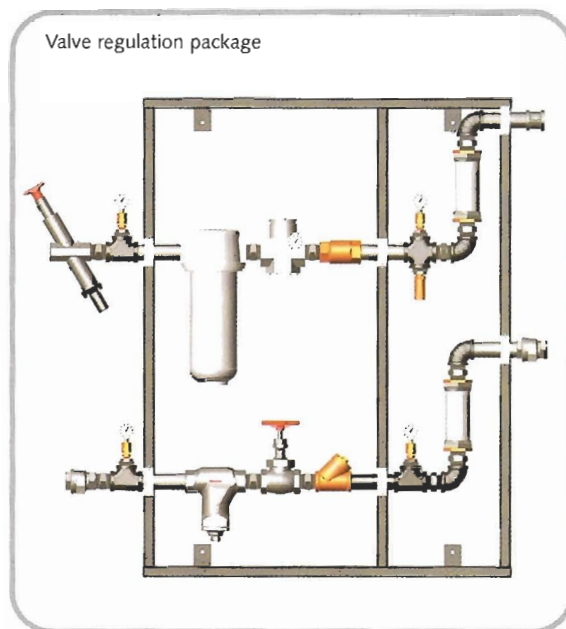

Standard Valve Regulation Packages are available with air and liquid inlets in three sizes: 1/2", 1" and 1-1/2". All components are assembled on a wall-mountable, powder-coated steel frame using vibration-resistant clamps. Fittings and components are brass or carbon steel.

Optional equipment includes solenoid valves for remote control, a NEMA 4 enclosure, filtration and electronic flow meters and a high-pressure hose kit to attach the regulation rack to the lance assembly.

Case Studies

Zhejiang Jinshou Cement Co, Ltd, China

Clinker and cement producer in Zhejiang Province, China, Zhejiang Jinshou Cement Co, was plagued by high gas temperatures and excessive wetting in the cooling tower on one of

its 2500tpd clinker lines. A high-pressure hydraulic cooling system wasn't able to provide adequate cooling and gas temperature exceeded the limits of the baghouse – resulting in burned filters and unscheduled downtime. In addition, the excess water in the cooling tower was causing sludge to form and an increase in maintenance time that further decreased production.

AutoJet Technologies, the turnkey systems division of Spraying Systems Co, provided the solution: an automated gas conditioning system using FloMax Air Atomising nozzles. The system consists of:

four FM25 FloMax nozzles.

Producing very small drops with minimal air consumption, FloMax nozzles provide the required gas cooling without wetting in the tower. Because the drops are so small, 100 per cent evaporation is achieved.

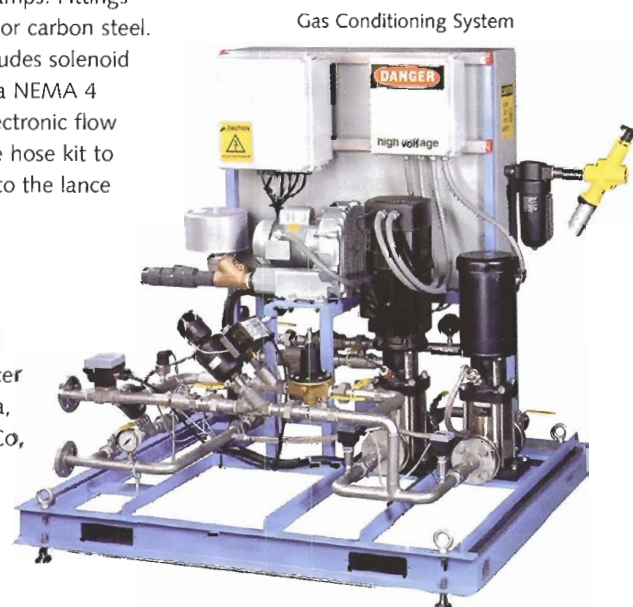

Variable Frequency Drive (VFD) integrated pumping system. The pumping system provides proportional liquid regulation and significant electricity savings. In addition, energy-efficient air regulation reduces air consumption and operating costs.

Model 2250 AutoJet Spray Controller. The controller monitors and adjusts all system components – nozzles, pumps, sensors – and all hydraulic and pneumatic components to ensure optimal performance despite changing process conditions. The controller also provides functionality that helps minimise maintenance time. For example, an air purge function is automatically activated should the controller determine reduced nozzle performance caused by clogging.

The controller operates independently of the plant's master control system but can be integrated if desired.

After several months of operation, Zhejiang Jinshou Cement Co reports a significant increase in production since downtime due to the gas conditioning system is minimal and lower labour, maintenance and operating costs.

Production declines spur Lafarge NA to opt for FloMax® Nozzles

To meet the exit temperature range required by the Environmental Protection Agency (EPA) during the hottest months of the year, Lafarge North America's plant in Grand Chain, IL USA was forced to reduce production by 20 per cent. Faced with an unacceptable revenue loss, Lafarge determined the older style air atomising nozzles in use could not lower gas temperature adequately when outdoor temperature and humidity increased during summer months.

Plant management quickly turned to Spraying Systems Co. to analyse the gas composition, volume and temperature range and recommend a solution. High-efficiency FloMax Air Atomising nozzles were selected for several reasons:

- the unique three-stage atomisation process produces very small drops using minimal air. These finely atomised drops generate more surface area per gallon for a more complete

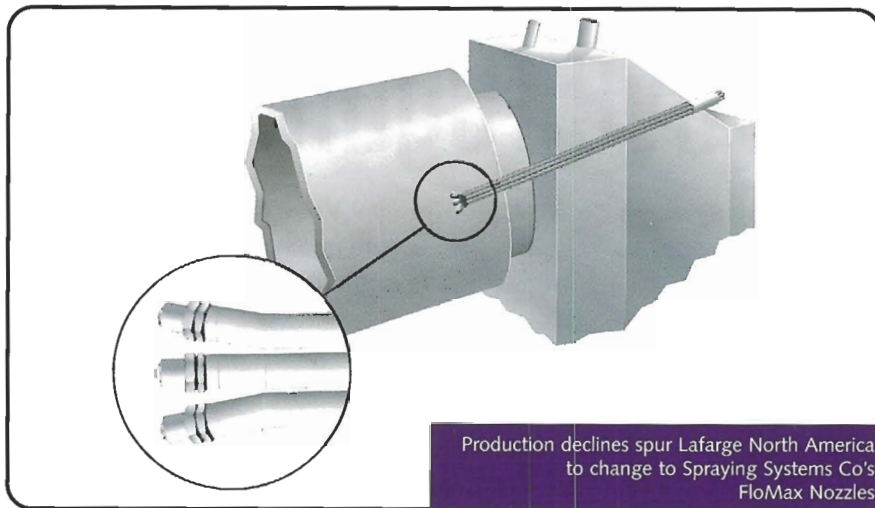

reaction and total absorption without wetting

the wide range of flow rates per nozzle results in lower installation and maintenance costs

the nozzles' efficient use of air lowers energy costs and extends compressor life. Once the nozzles were specified, the next critical issue was delivery and installation.

To speed the process, specialised lance assemblies and shuttle tubes were designed to fit existing entry points. The nozzles and lances were shipped in a matter of weeks and Lafarge was able to return to full production. In fact, Lafarge has been able to increase production while maintaining compliance with EPA regulations because of the effective and efficient cooling provided by FloMax nozzles.

Holcim (US) Inc meets pollution regulations & maintains production levels

The Holcim (US) Inc. cement manufacturing plant in Clarksville, MO USA is the home of one of the largest wet process kilns in operation today. This single kiln, 25ft (7.6m) in diameter, produces 1.4 per cent of the gray cement clinker produced in the USA. This translates into more than 4000tpd.

To achieve kiln exit gas temperatures below 400°F (204°C) and further reduce the formation of dioxins and furans, Holcim Clarksville needed a single-source gas cooling system that could process 750,000acfm without adding excess moisture to the system. Holcim was not willing to risk wetting and increased maintenance time.

FloMax nozzles were selected to cool and evaporate up to 200gpm (757 l/min) in the windbox based on low dwell time and 100 per cent evaporation. The nozzles are part of an AutoJet Gas Conditioning System that provides automated operation and ensures optimal nozzle performance. Lances are controlled independently of each other, facilitating kiln start up and adjustment of spray nozzle parameters such as air pressure, liquid pressures, flow rates and temperature.

Spraying Systems Co also engineered and fabricated custom lances and mounting hardware to simplify system installation.

